

MEASUREMENT OF TOTAL LOAD USING STRAIN GAGE BASED TRANSDUCERS IN PARALLEL

The case sometimes arises when more than one transducer is required to interface a system to measure the loads across that interface. This technical note discusses the consequences of this so-called "paralleling" of transducers with regards to sensitivity, shunt calibration, and potential errors. The case of two transducers paralleled will be treated here but the results can be extended to paralleling three or more transducers. It is assumed the transducers are composed of fully active bridge arms with each pair of adjacent arms subjected to equal and opposite strains. Constant voltage bridge excitation is also assumed.

When transducers are arranged in parallel they are done so both in a mechanical and electrical sense as shown below in figures 1 and 2 respectively.

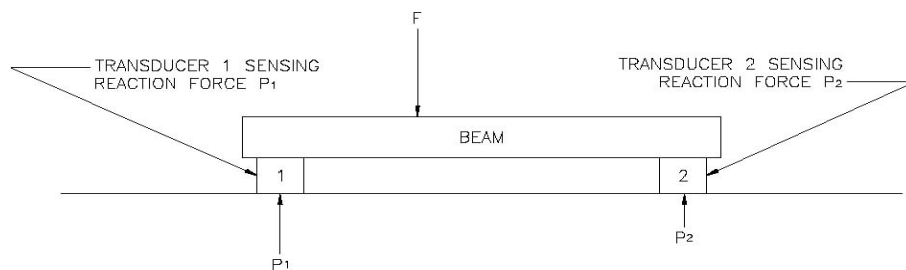

Figure 1. Transducers 1 and 2 form a parallel load path for force F.

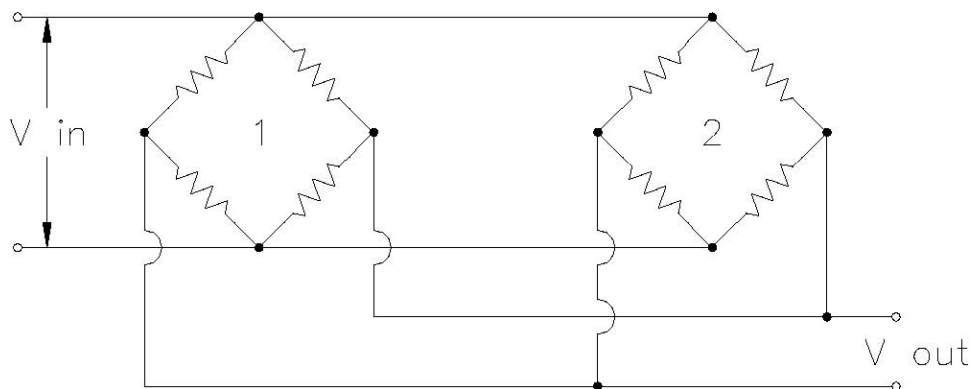

Figure 2. Wheatstone bridges of transducers 1 and 2 wired in parallel.

We begin by examining a representative schematic of a single loaded transducer as shown in figure 3.

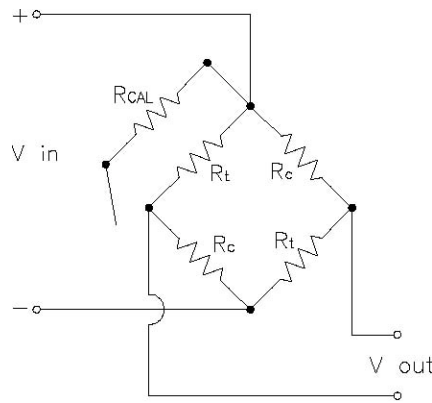

Figure 3. Single loaded transducer circuit representation. The subscripts "t" and "c" refer to bridge arms in tension and compression respectively.

A simplified yet equivalent schematic of figure 3 is given in figure 4.

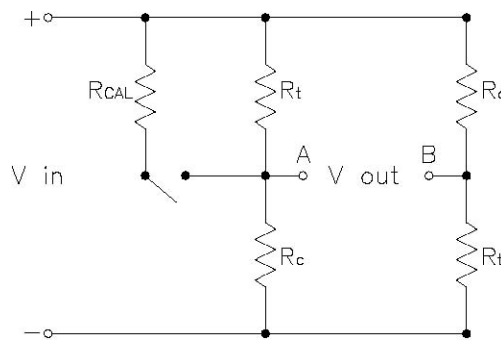

Figure 4. Equivalent circuit of figure 3.

With zero load applied, $R_t = R_c = R$ so figure 4 can be redrawn as shown in figure 5.

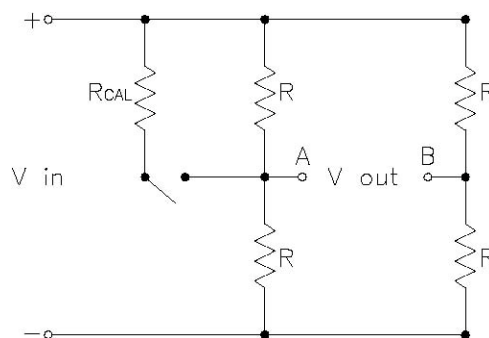

Figure 5. Circuit of figure 4 with no load applied.

We now examine the representative schematic of two loaded paralleled transducers as shown in figure 6.

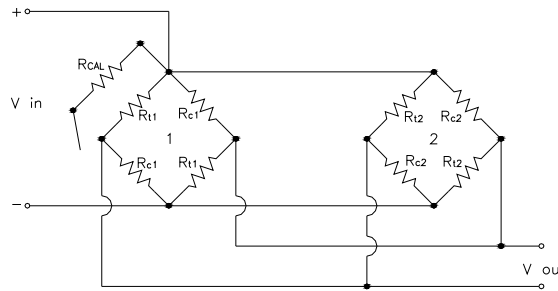

Figure 6. Two loaded paralleled transducers, 1 and 2, where again the subscripts "t" and "c" refer to bridge arms in tension and compression respectively.

A simplified yet equivalent schematic of figure 6 is given in figure 7.

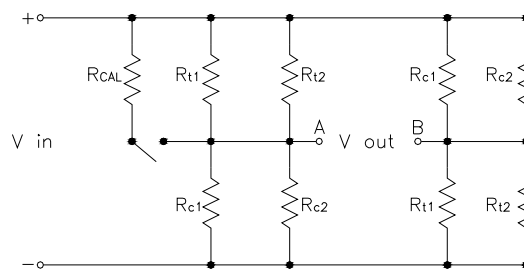

Figure 7. Equivalent circuit of figure 6.

With zero load applied to the transducers, $R_{t1} = R_{t2} = R_{c1} = R_{c2} = R$ so that under this condition the schematic may be further simplified as shown in figure 8.

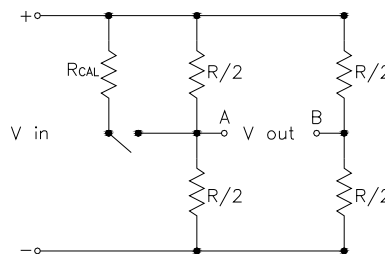

Figure 8. Equivalent circuit of Figure 7 when transducers are unloaded.

We are now in a good position where we can compare the relation between the shunt output of a single transducer, S_1 (see figure 5) to that of two paralleled transducers, S_2 (see figure 8). To do this we use the relationship that the output of a Wheatstone bridge due to changing the resistance in one arm of the bridge is essentially* proportional to the change in resistance of that arm divided by its unchanged resistance:

$$\frac{\Delta R_{arm}}{R_{arm}} \propto V_{out}$$

Therefore,

$$\frac{S_2}{S_1} = \frac{\left(\frac{\Delta R_{arm}}{R_{arm}} \right)_{parallel}}{\left(\frac{\Delta R_{arm}}{R_{arm}} \right)_{single}} = \frac{\left(\frac{R - \frac{R_{cal} \left(\frac{R}{2} \right)}{2}}{R_{cal} + \frac{R}{2}} \right) \frac{R}{2}}{\left(\frac{R - \frac{R_{cal} (R)}{R_{cal} + R}}{R} \right)} = \frac{R_{cal} + R}{2R_{cal} + R}$$

Where R_{cal} is the value of the shunt resistor. Since $R \ll R_{cal}$ we have:

$$\frac{S_2}{S_1} \approx \frac{1}{2}$$

or,

$$S_2 \approx \frac{1}{2} S_1$$

This relation can be extended for "i" transducers so that in general,

$$S_i \approx \frac{1}{i} S_1$$

*The output of the single-active arm Wheatstone bridge is inherently non-linear with $\Delta R_{arm}/R_{arm}$ but this non-linearity is negligible with the arm and shunt resistance values typically used.

We now examine how sensitivity is affected by paralleling transducers. To begin, we alternately express the values of the resistances in the bridge arms of figure 7 as :

$$R_{t1} = R + \Delta R_1$$

$$R_{t2} = R + \Delta R_2$$

$$R_{c1} = R - \Delta R_1$$

$$R_{c2} = R - \Delta R_2$$

The resistances in the bridge's tension and compression arms respectively are now:

$$R_t = R_{t1} \parallel R_{t2} = \frac{R^2 + R \cdot \Delta R_1 + R \cdot \Delta R_2 + \Delta R_1 \cdot \Delta R_2}{2R + \Delta R_1 + \Delta R_2} \quad (2)$$

$$R_c = R_{c1} \parallel R_{c2} = \frac{R^2 - R \cdot \Delta R_1 - R \cdot \Delta R_2 + \Delta R_1 \cdot \Delta R_2}{2R - \Delta R_1 - \Delta R_2} \quad (3)$$

This allows figure 7 to be redrawn as shown in figure 9 where R_t and R_c are from equations (2) and (3).

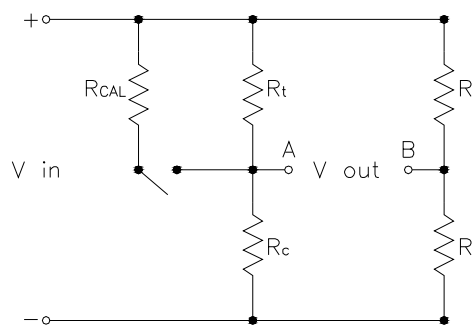

Figure 9. Simplification of figure 7.

Applying the voltage divider rule to the circuit in figure 9 gives:

$$V_A = \frac{V_{in} R_c}{R_t + R_c}$$

and

$$V_B = \frac{V_{in} R_t}{R_t + R_c}$$

Therefore,

$$V_{out} = V_B - V_A = \frac{V_{in}(R_t - R_c)}{R_t + R_c}$$

Substituting equations (2) and (3) into (4) and ignoring second order terms in ΔR_1 and ΔR_2 since they are relatively very small gives:

$$V_{out\ parallel} = \left(\frac{\Delta R_1 + \Delta R_2}{2R} \right) V_{in} \quad (4)$$

Suppose each transducer is subjected to equal loads *and* their sensitivities are the same, then $\Delta R_1 = \Delta R_2 = \Delta R$ and (5) becomes:

$$V_{out\ parallel} = \left(\frac{\Delta R}{R} \right) V_{in} \quad (5)$$

Now if the only change we make is to wire each transducer separately (i.e. no longer electrically paralleled but still mechanically paralleled and hence each subjected to equally divided loads as before) then in figure 4, $R_t = R + \Delta R$ and $R_c = R - \Delta R$ and application of the voltage divider rule gives:

$$V_{out\ single} = V_B - V_A = \left(\frac{(R + \Delta R) - (R - \Delta R)}{R + \Delta R + R - \Delta R} \right) V_{in} = \left(\frac{\Delta R}{R} \right) V_{in}$$

Therefore, in the two combined parallel case the *total* load is proportional to:

$$\frac{\Delta R}{R}$$

Where in the two separate singles case the *total* load is proportional to:

$$\frac{\Delta R}{R} + \frac{\Delta R}{R} = \frac{2\Delta R}{R}$$

We see therefore that there is a 50% decrease in sensitivity when two transducers are paralleled. This can be compensated for by increasing the gain of the signal conditioning amplifier by a factor of two. But recall equation (1) indicates that the shunt output of two paralleled transducers is one half of the output of a single transducer; therefore, to double the gain for the parallel system, one can simply adjust the amplifier gain to the same shunt calibration value one would use if a single transducer was utilized.

In the preceding discussion it was stipulated that the load was shared equally between the two paralleled transducers. What if the load is not divided equally? It turns out that if both transducers are of the same sensitivity, then $\Delta R_1 + \Delta R_2$ in equation (5) will always equal $2\Delta R$, and the parallel system will thus give the correct sum. The reasoning is as follows:

Consider transducers 1 and 2 subjected to unequal loads P_1 and P_2 respectively as shown in figure 10.

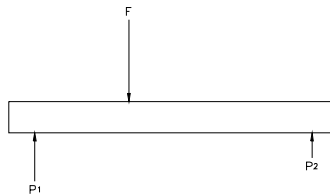

Figure 10.

Let

$$F = P_1 + P_2 = k_1 \Delta R_1 + k_2 \Delta R_2$$

where k_1 and k_2 are transducer sensitivity factors relating the change in resistances ΔR_1 and ΔR_2 to the forces P_1 and P_2 respectively. The higher the k the lower (in proportion) the transducer's sensitivity. Note that k is directly related to the shunt calibration equivalent, therefore, the higher the shunt calibration equivalent the lower the transducer's sensitivity (for example in mV/V) and vice versa.

If $k_1 = k_2 = k$ (i.e. same sensitivity) then the above equation gives $F = k(\Delta R_1 + \Delta R_2)$, but for the special case of same sensitivities with equal loading $F = k(2\Delta R)$, therefore $\Delta R_1 + \Delta R_2 = 2R$.

CONCLUSION

The necessary and sufficient conditions for paralleling two or more transducers to measure the total load are that they be of the same sensitivity (i.e. have identical shunt calibration equivalents) and that the shunt calibration equivalent used for the paralleled system be the same as the value given for the transducers. For those cases when transducers with the same sensitivities are not available, transducers should be selected that have "nearly equal" shunt calibration equivalents of which an average is taken and used as the paralleled system's shunt calibration equivalent.^{1*}

The next section addresses the amount of error associated with the compromise of using an average shunt calibration equivalent with paralleled transducers of unequal sensitivities.

1. * If calibration via sensitivity in terms of mV/V is used instead of calibration via shunt calibration equivalent, then the mV/V values among the transducers should be averaged and then *divided by the number of transducers paralleled*. This division effectively compensates for the decrease of sensitivity associated with paralleling transducers as described earlier.

EVALUATION OF THE ERROR ASSOCIATED WITH AVERAGING THE SHUNT CALIBRATION EQUIVALENTS OF PARALLELED TRANSDUCERS

Recall equation (6), which is a relation between the true total force and the transducers' sensitivity factors for a parallel system composed of two transducers:

$$F = P_1 + P_2 = k_1 \Delta R_1 + k_2 \Delta R_2 \quad (6) \text{ repeated}$$

If we replace k_1 and k_2 by the average of the two we get:

$$F_{estimate} = \frac{k_1 + k_2}{2} \Delta R_1 + \frac{k_1 + k_2}{2} \Delta R_2 = \frac{k_1 + k_2}{2} (\Delta R_1 + \Delta R_2)$$

Where $F_{estimate}$ is the estimated total force since the sensitivity of our transducers are not necessarily equal.

We can determine the percent error of this estimate from:

$$(\kappa - 1)100\%$$

where,

$$\kappa = \frac{F_{estimate}}{F} = \frac{\frac{k_1 + k_2}{2} \left(\frac{\alpha}{\beta} + 1 \right)}{k_2 (\alpha + 1)}$$

with

$$\alpha = \frac{P_1}{P_2} \quad ; \quad \beta = \frac{k_1}{k_2}$$

One can verify $\kappa = 1$ when $\beta = 1$. Note the special case of when $\alpha = \beta$ then $\kappa = 1$. We see that the magnitude of error is not only dependant upon transducer sensitivities, but also upon how the load is divided among the transducers as represented by α . The extension to three transducers gives:

$$\kappa = \frac{\frac{k_1 + k_2 + k_3}{3} \left(\frac{\alpha}{\beta} + 1 + \frac{\lambda}{\gamma} \right)}{k_2 (\alpha + 1 + \lambda)}$$

where

$$\alpha = \frac{P_1}{P_2} \quad ; \quad \lambda = \frac{P_3}{P_2} \quad ; \quad \beta = \frac{k_1}{k_2} \quad ; \quad \gamma = \frac{k_3}{k_2}$$

EXAMPLES

EXAMPLE 1:

What is the percent error due to averaging the cal factors of two paralleled transducers with 100kohm shunt cal equivalents of 680 pounds and 720 pounds if the load is divided equally?

$$\text{Let } k_1 = 680, \text{ then } k_2 = 720 \text{ and } \alpha = \frac{P_1}{P_2} = 1 ; \beta = \frac{k_1}{k_2} = \frac{680}{720} = 0.9444$$

$$\therefore \kappa = \frac{\frac{680 + 720}{2} \left(\frac{1}{0.9444} + 1 \right)}{720(1 + 1)} = 1.0008 \Rightarrow 0.08\% \text{ error}$$

What if transducer 1 sees twice as much load as transducer 2?

Now $\alpha = 2$:

$$\therefore \kappa = \frac{\frac{680 + 720}{2} \left(\frac{2}{0.9444} + 1 \right)}{720(2 + 1)} = 1.0104 \Rightarrow 1.04\% \text{ error}$$

What if transducer 2 sees twice as much load as transducer 1?

Now $\alpha = 0.5$:

$$\therefore \kappa = \frac{\frac{680 + 720}{2} \left(\frac{0.5}{0.9444} + 1 \right)}{720(0.5 + 1)} = 0.9913 \Rightarrow -0.87\% \text{ error}$$

EXAMPLE 2:

What is the percent error due to averaging the cal factors of two paralleled transducers with 100kohm shunt cal equivalents of 600 pounds and 300 pounds if the load is divided equally?

$$\text{Let } k_1 = 600, \text{ then } k_2 = 300 \text{ and } \alpha = \frac{P_1}{P_2} = 1 ; \beta = \frac{k_1}{k_2} = \frac{600}{300} = 2$$

$$\therefore \kappa = \frac{\frac{600+300}{2} \left(\frac{1}{2} + 1 \right)}{300(1+1)} = 1.1250 \Rightarrow 12.5\% \text{ error}$$

What if transducer 1 sees twice as much load as transducer 2?

Now $\alpha = 2$:

$$\therefore \kappa = \frac{\frac{600+300}{2} \left(\frac{2}{2} + 1 \right)}{300(2+1)} = 1.0000 \Rightarrow 0\% \text{ error}$$

What if transducer 2 sees twice as much load as transducer 1?

Now $\alpha = 0.5$:

$$\therefore \kappa = \frac{\frac{600+300}{2} \left(\frac{0.5}{2} + 1 \right)}{300(0.5+1)} = 1.2500 \Rightarrow 25\% \text{ error}$$