

Wheel Torque Transducer

Model TW15.0

- 7000 lb-ft capacity
- Adapts to 15" and larger wheels
- Environmentally protected
- Temperature compensated
- Rugged stainless steel construction
- Consistent sensitivity among all units
- Configured to reduce magnetic sensitivity



Description

Michigan Scientific's *TW15.0 Wheel Torque Transducer* is ideal for measuring wheel torque on both light and medium duty trucks. Designed to attach to adapters that simulate production wheel rims, this unit provides one channel of torque data. The adapter system is fabricated by generating a profile of the original wheel rim and designing a hub adapter and rim adapter that duplicate the critical dimensions of the original rim. The hub adapter fastens to the interior bolt circle of the torque transducer, and the rim adapter fastens to the exterior bolt circle. The versatility of this system allows the torque transducer to be used with various wheel rim designs.

Both the torque and combined steer/camber moment load ratings of the *TW15.0* transducer are 7000 lb-ft. High grade stainless steel material and weatherproof sealing combine to provide excellent resistance to corrosion and environmental conditions. Temperature compensation ensures stable output throughout a wide temperature range. In addition, all wires are precisely located to reduce sensitivity to magnetic effects.

Specifications

| | |
|---|---|
| Maximum Load Capacity | 7000 lb-ft (9492 N-m) |
| Full Scale Load | 7000 lb-ft (9492 N-m) |
| Full Scale Output | 1.5mV/V nominal |
| Sensor | 4 arm strain gage bridge |
| Nonlinearity | 0.1% of full scale output |
| Hysteresis | 0.05% of full scale output |
| Repeatability | 0.05% of full scale output |
| Zero Balance | Within $\pm 5.0\%$ of rated output at zero load |
| Bridge Resistance | 525 Ω nominal |
| Temperature Range, Compensated | 75°F to 250°F (24°C to 121°C) |
| Temperature Effect on Zero | 0.0008% full scale/ °F (0.0015% full scale/ °C) |
| Temperature Range, Useable (Short Term) | -40°F to 350°F (-40°C to 177°C) |
| Temperature Range, Useable (Long Term) | -40°F to 300°F (-40°C to 149°C) |
| Excitation Voltage, Maximum | 10V DC or AC rms |
| Insulation Resistance, Bridge/Case | Exceeds 5000 M Ω |
| Output Connector | Bendix PTY02E-8-4P |
| Mating Connector | Bendix PT06E-8-4S (SR) |

8500 Ance Road
Charlevoix, MI 49720
Tel: 231-547-5511
Fax: 231-547-7070

MICHIGAN SCIENTIFIC
<http://www.michsci.com>
Email: miscinfo@michsci.com
corporation

321 East Huron Street
Milford, MI 48381
Tel: 248-685-3939
Fax: 248-684-5406

Rev: 4/28/12

Wheel Torque Transducer

TW15.0 Configuration

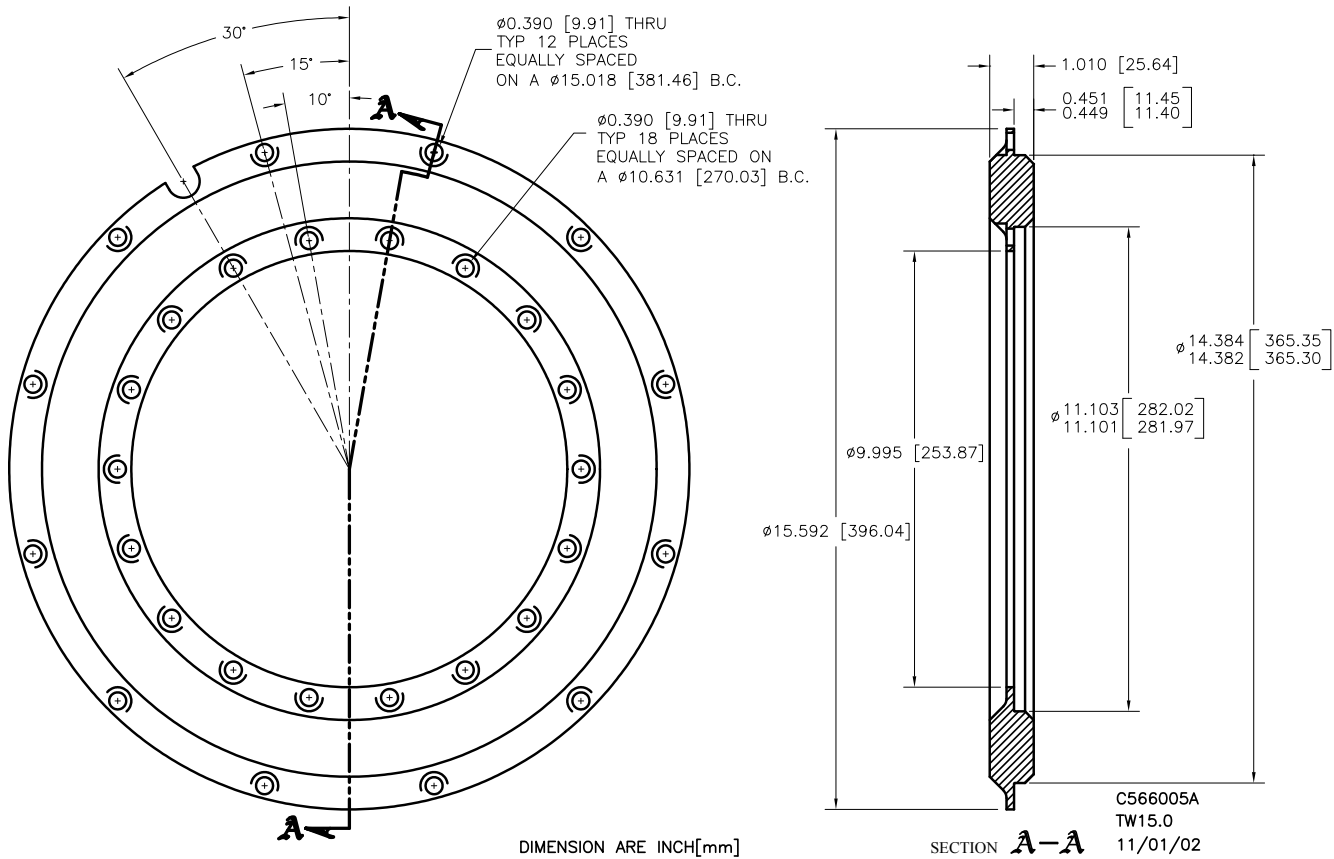

Ordering Options

Special units are available for high temperature applications.

Custom designs with alternative output sensitivities and load capacities may also be ordered.

Michigan Scientific offers a fully weatherproof slip ring, encoder, and amplifier instrumentation assembly to be used with all Wheel Torque Transducers. Refer to the product literature section "Instrumentation Assemblies" for more information.

8500 Ance Road
 Charlevoix, MI 49720
 Tel: 231-547-5511
 Fax: 231-547-7070
 Rev: 4/28/12

MICHIGAN SCIENTIFIC
 corporation

321 East Huron Street
 Milford, MI 48381
 Tel: 248-685-3939
 Fax: 248-684-5406