

Shift Lever Peg Transducer

Model TR1D-SL1

- 100 lb Capacity
- Overload protection
- Environmentally protected
- Temperature compensated
- Rugged stainless steel construction

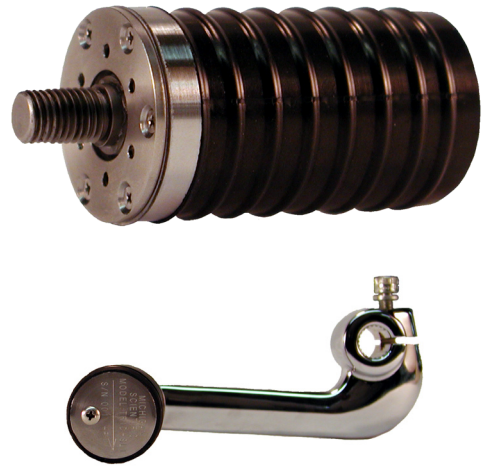

Description

Michigan Scientific's *TR1D-SL1 Shift Lever Peg Transducer* was originally designed for use on motorcycles. The peg measures bidirectional applied loads along the axis of the engraved arrow on its outboard end. A positive strain gage bridge output is obtained from radial loads applied in the direction of the engraved arrow. Sensitivity of the transducer remains constant for load applied anywhere along its length from outboard to inboard ends.

The transducer is designed with internal mechanical stops for the gaged beam elements. This protects them from being damaged (yielding) by an overload condition. The strength of the peg's mounting thread sets the maximum radial load capacity.

High grade stainless steel material and weatherproof sealing combine to provide excellent resistance to corrosion and environmental conditions. Temperature compensation of the transducer ensures stable output through a wide temperature range.

A shielded 4 conductor cable exits the transducer in a radial direction at its inboard end. The transducer is normally installed so that the cable points towards the front of the bike. The cable is then looped around and routed along the back or bottom side of the shift lever. Cable ties and fusion tape are then used to secure the cable.

Specifications

Maximum Load Capacity	100 lbs
Full Scale Load	100 lbs
Full Scale Output	1.5 mV/V
Overload Capacity (% above maximum load capacity)	40%
Sensor	4 arm strain gage bridge
Nonlinearity	< 0.2% of full scale
Hysteresis	0.05% of full scale
Repeatability	0.05% of full scale
Bridge Resistance	700 Ω
Temperature Range, Compensated	-40°F to 200°F (24°C to 93°C)
Insulation Resistance, Bridge/Case	Exceeds 20000 M Ω
Excitation Voltage, Maximum	10 V DC or AC rms

8500 Ance Road
Charlevoix, MI 49720
Tel: 231-547-5511
Fax: 231-547-7070

MICHIGAN SCIENTIFIC
corporation
<http://www.michsci.com>
Email: mscinfo@michsci.com

321 East Huron Street
Milford, MI 48381
Tel: 248-685-3939
Fax: 248-685-5406

Rev: 4/28/12

Shift Lever Peg Transducer

TR1D-SL1 Configuration

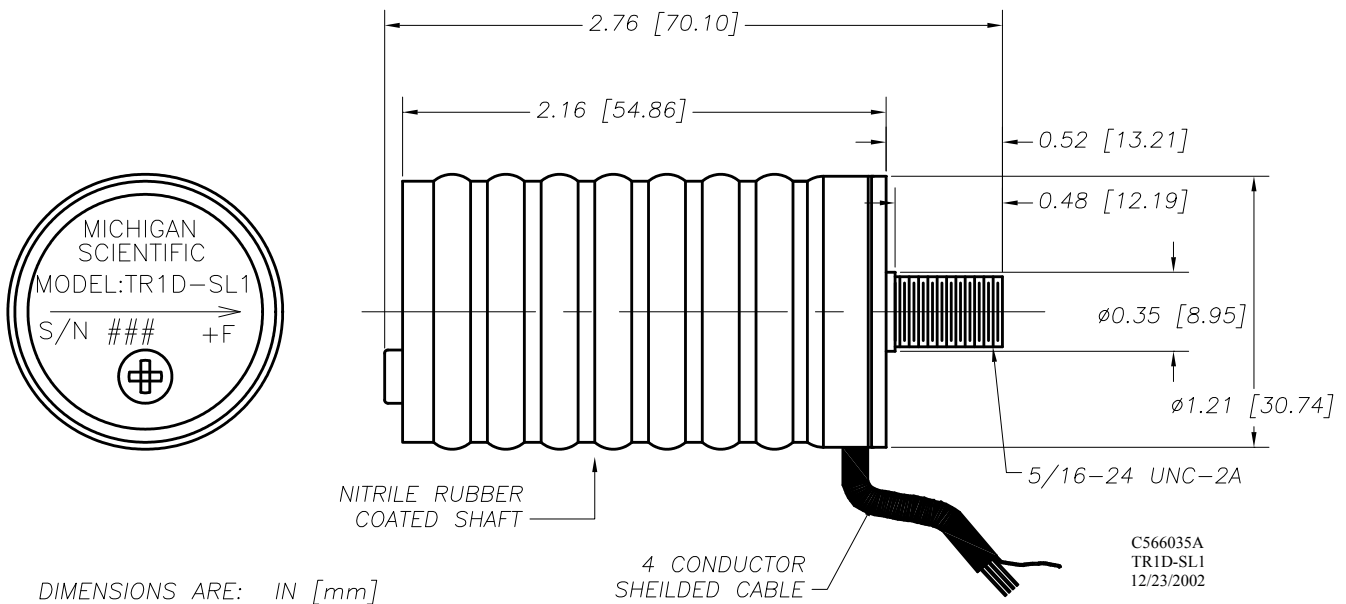

Ordering Options

Other peg mounting configurations could be used in place of the 5/16-24 thread. Contact Michigan Scientific if you require a different mounting scheme.

8500 Ance Road
Charlevoix, MI 49720
Tel: 231-547-5511
Fax: 231-547-7070
Rev: 4/28/12

MICHIGAN SCIENTIFIC
corporation
<http://www.michsci.com>
Email: mscinfo@michsci.com

321 East Huron Street
Milford, MI 48381
Tel: 248-685-3939
Fax: 248-685-5406