

DC Remote Amplifier Control Unit

Model PS-DC

- Controls up to 22 spinning strain gage amplifiers*
- Remote bridge excitation On/Off capability
- Remote electronic shunt calibration capability
- Bipolar power supply for spinning amplifiers
- Wide input voltage range
- Ideal for automotive applications

* 5 Volt bridge excitation @ 350Ω



Description

Michigan Scientific's *DC Amplifier Control Unit* is a complete system for controlling all Michigan Scientific Spinning Amplifiers. The *PS-DC* powers the amplifiers, controls excitation to strain gage bridges, and commands spinning strain gage amplifiers to apply their internal shunt calibration resistor to the appropriate arm of the strain gage bridge. The bridge excitation off feature allows the user to detect self-generated system response (noise) from undesired environmental conditions.

A power supply of 10 to 36V DC is required to operate the *PS-DC* which makes it ideal for automotive applications.

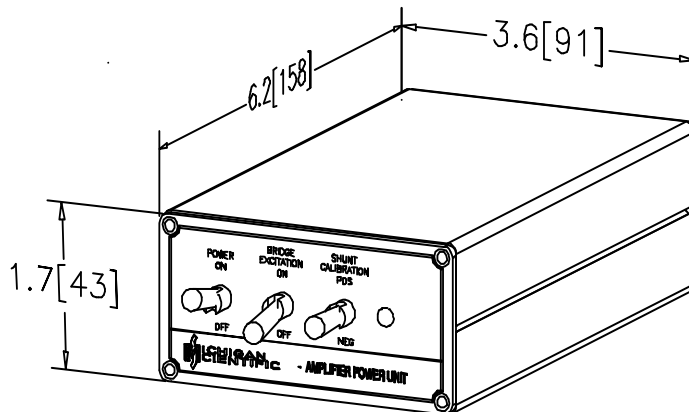

DIMENSIONS ARE INCH[mm]

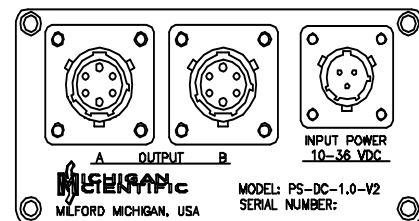

REAR PANEL

C566038A
PD-DC
07/11/2005

8500 Ance Road
Charlevoix, MI 49720
Tel: 231-547-5511
Fax: 231-547-7070

Rev: 4/28/12

MICHIGAN SCIENTIFIC
corporation

<http://www.michsci.com>
Email: mscinfo@michsci.com

321 East Huron Street
Milford, MI 48381
Tel: 248-685-3939
Fax: 248-685-5406

DC Remote Amplifier Control Unit

Specifications

PARAMETER	SPECIFICATIONS
OUTPUT	
Voltage	±15V
Maximum Voltage Error (No Load)	± 200mV
Ripple Voltage (No Load)	± 200mV
Maximum Source Resistance	1Ω
Power Supply Rejection	50dB
Temperature Coefficient	0.02% / °C
Maximum Current	1 A
Maximum Transient Response	500 μs
INPUT	
Voltage	10 to 36 VDC
Max Current @ Full Load	5 A
ENVIRONMENT	
Operation	-25 °C to +70 °C (-13 °F to +158 °F)
Storage	-50 °C to +100 °C (-58 °F to +212 °F)

Controls

Power (On/Off):	Activates the Amplifier Control Unit and illuminates LED.		
Bridge Excitation (On/Off):	When used with a modular strain gage spinning amplifier, this turns the excitation to the bridge on or off without turning off the amplifier. This is done by inverting the polarity of the ± 15V supply pins.		
	Bridge Excitation ON OFF	Output Terminal A +15 VDC -15 VDC	Output Terminal C -15 VDC +15 VDC
Shunt Calibration: (Positive/Center/Negative)	Remotely applies positive or negative shunt resistance across bridge terminals when used with a modular strain gage spinning amplifier.		
	Shunt Calibration POSITIVE CENTER NEGATIVE		Output Terminal F +15 VDC High Impedance -15 VDC
Indicator LED:	Illuminated whenever power is on.		
	LED RED GREEN	Condition Over-current warning, shunt calibration condition or bridge excitation off. Normal operation	

Electrical Connections

Input Power		Output	
3 Pin Male Connector PT02E-8-3P*		6 Pin Female Connector PT02E-10-6S*	
Terminal	Function	Terminal	Function
A	+10 to +36 VDC	A	+15V
B	DC Input Power Ground	B	15V Common
C	N/C	C	-15V
		D	15V Common
		E	DC Input Power Ground
		F	Calibration Control

*Mating connectors are provided with new units.

8500 Ance Road
Charlevoix, MI 49720
Tel: 231-547-5511
Fax: 231-547-7070
Rev: 4/28/12

MICHIGAN SCIENTIFIC
corporation

321 East Huron Street
Milford, MI 48381
Tel: 248-685-3939
Fax: 248-685-5406

<http://www.michsci.com>

Email: mscinfo@michsci.com