

# Small Vehicle Wheel Load Transducer, 6-Axis

## Model LW9.5

- 8000 lb (35.6 kN) Radial Capacity
- 4000 lb (17.8 kN) Lateral Capacity
- Measures 3 forces and 3 moments
- Adapts to 10" and larger wheels
- Low cross axis sensitivity
- Environmentally protected
- Temperature compensated
- Rugged stainless steel construction
- Configured to minimize magnetic sensitivity



## Description

The *LW9.5 Wheel Load Transducer* is capable of measuring all of the wheel forces and moments on ATV's (all terrain vehicles), utility vehicles and mini automobiles. It provides independent output signals for vertical, lateral, and longitudinal forces as well as camber, steer and torque moments. It is completely weatherproof, making it ideal for off-road measurements. It can also be used to monitor and control laboratory tests.

High grade stainless steel material and weatherproof sealing combine to provide excellent resistance to corrosion and environmental conditions. Temperature compensation of the Wheel Load Transducer ensures stable output throughout a wide temperature range. In addition, all wires are precisely arranged to minimize sensitivity to magnetic fields that may be encountered with rotating transducers.

An optional amplifier package is available that bolts directly on to the *LW9.5 Wheel Load Transducer*. The optional amplifier package provides regulated power to the transducer's strain gage bridges, amplifies the signals and incorporates remote electrical calibration.

## Specifications

Maximum Force Capacity, [Fx, Fz] (radial)	8,000 lb. (35.6 kN)
[Fy] (lateral)	4,000 lb. (17.8 kN)
Maximum Torque Capacity [Mx, My, Mz] (all axes)	4,000 lb-ft. (5.4 kN-m)
Full Scale Output	1 mV/V nominal, ( $\pm 10$ Volts with optional amplifier)
Sensor	4 arm strain gage bridges
Nonlinearity	<1% of full scale output
Hysteresis	<1% of full scale output
Repeatability	Within 1% of full scale output
Zero Balance	Within $\pm 2\%$ rated output
Cross Axis Sensitivity	<2% full-scale with amplifier
Temperature Range, Compensated	-40°F to 200°F (-40°C to 93°C)
Operating	-40°F to 257°F (-40°C to 125°C)
Radial Sensitivity Variation	<1% full-scale
Bridge Resistance	700 to 1400 ohm, axis dependent
Insulation Resistance, Bridge/Case	Exceeds 1000M $\Omega$

8500 Ance Road  
Charlevoix, MI 49720  
Tel: 231-547-5511  
Fax: 231-547-7070

**MICHIGAN SCIENTIFIC**  
corporation  
<http://www.michsci.com>  
Email: [mcsinfo@michsci.com](mailto:mcsinfo@michsci.com)

321 East Huron Street  
Milford, MI 48381  
Tel: 248-685-3939  
Fax: 248-684-5406

Rev: 4/28/12

# Small Vehicle Wheel Load Transducer, 6-

## LW9.5 Configuration

Shown with Optional Amplifier, Slip Ring, and Wheel and Hub Adapters

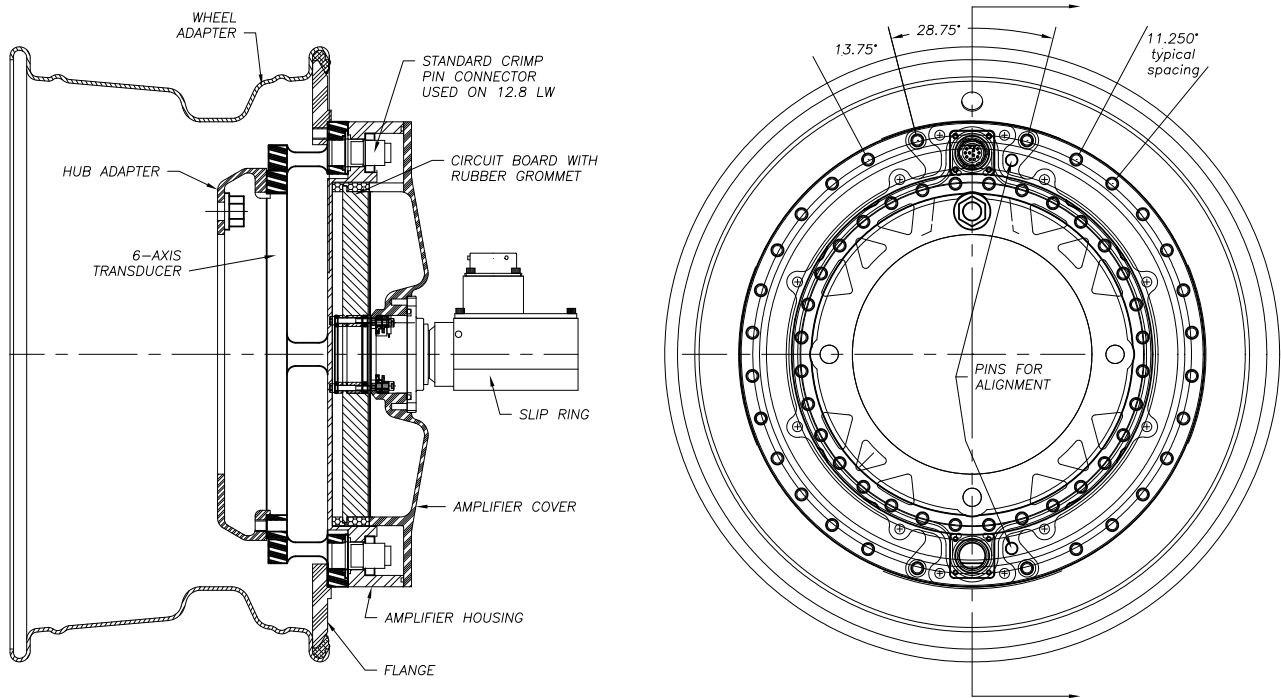

C566054D  
06/28/2004

## Ordering Options

Custom designs with alternative output sensitivities and load capacities may also be ordered.

Michigan Scientific offers a fully weatherproof slip ring, resolver, and amplifier instrumentation assembly to be used with all wheel torque or load transducers. Refer to the product literature section "Instrumentation Assemblies" for more information.

8500 Ance Road  
Charlevoix, MI 49720  
Tel: 231-547-5511  
Fax: 231-547-7070  
Rev: 4/28/12

**MICHIGAN SCIENTIFIC**  
corporation

<http://www.michsci.com>  
Email: [miscinfo@michsci.com](mailto:miscinfo@michsci.com)

321 East Huron Street  
Milford, MI 48381  
Tel: 248-685-3939  
Fax: 248-684-5406