

Weatherproof Tubular Slip Ring Assembly

Model B7-1.24W

(smaller diameter for limited space applications)

- Ideal for automotive half shaft
- Mounts on shafts up to 1.24" in diameter
- Rugged stainless steel construction
- Permanently lubricated bearings
- Instrumentation quality rings and brushes



Description

Michigan Scientific's *B7-1.24W Weatherproof Slip Ring Assembly* is ideal for applications that require a slip ring to be mounted directly on a rotating shaft. The *B7-1.24W* was designed to make long-term, all-weather (not submersible), torque measurements on automotive half shafts, but can be used in other applications with a shaft up to 1.24" in diameter. The slip ring sealing system protects against water spray, grit, dust, mud, slush, and snow.

Connections to strain gages, thermocouples, and other sensors are made via color-coded solder terminals located on the slip ring rotor. Each slip ring assembly includes a 15 ft stator cable with a protective rubber boot for the connector at the slip ring.

Specifications

	B7-1.24W
Circuits	7
Current Capacity	1A
Temperature Range, slip ring	-40°F to 300°F (-40°C to 149°C)
Maximum Peak Noise**	0.1Ω
RPM Rating	3500 RPM
Width	2.827 in (71.8 mm)
Diameter	2.953 in (75.0 mm)
Weight	2.1lbs (95 kg)
** Resistance variation across slip ring contact. Intermittent speed burst up to 5500 RPM	

8500 Ance Road
Charlevoix, MI 49720
Tel: 231-547-5511
Fax: 231-547-7070

Rev: 4/28/12

MICHIGAN SCIENTIFIC
<http://www.michsci.com>
Email: miscinfo@michsci.com
corporation

321 East Huron Street
Milford, MI 48381
Tel: 248-685-3939
Fax: 248-685-5406

Weatherproof Tubular Slip Ring Assembly

B7-1.24W Configurations

B7-1.24W with solder terminals

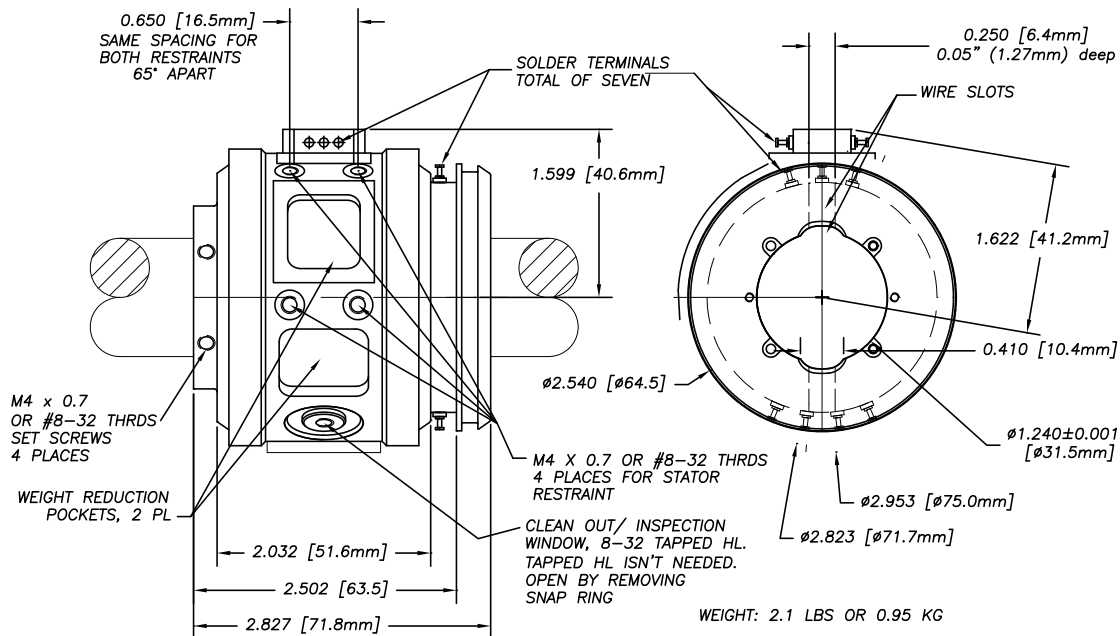

B7-1.24W with Lemo connector

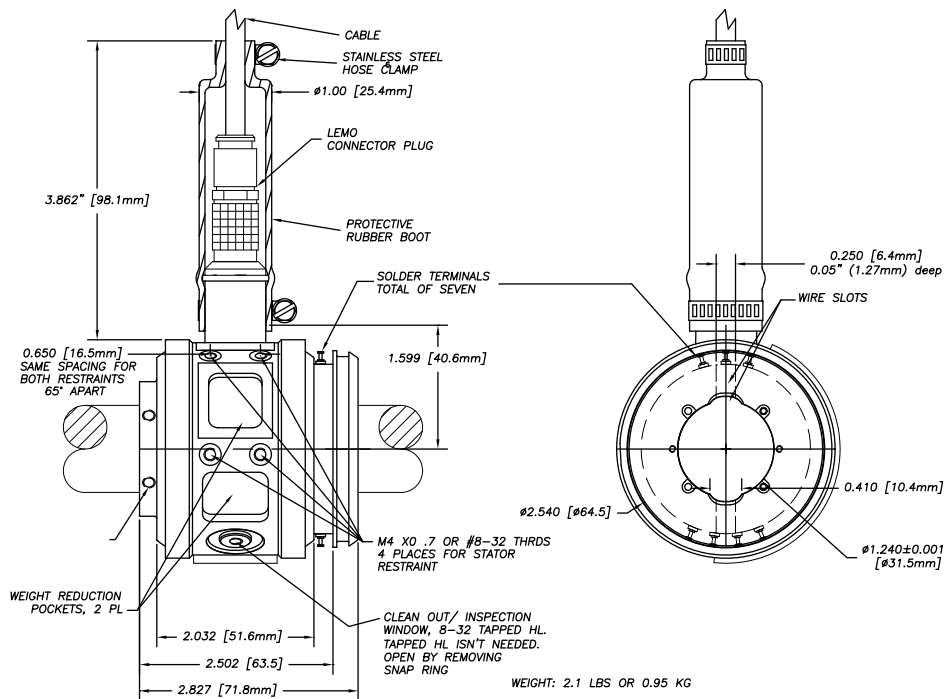

8500 Ance Road
Charlevoix, MI 49720
Tel: 231-547-5511
Fax: 231-547-7070
Rev: 4/28/12

MICHIGAN SCIENTIFIC
corporation
<http://www.michsci.com>
Email: mcsinfo@michsci.com

321 East Huron Street
Milford, MI 48381
Tel: 248-685-3939
Fax: 248-685-5406