

High Resolution Wheel Torque Transducer

Models TW12.8HRMS175, TW12.8HRMS800

- Measures up to 175 lb-ft and 800 lb-ft
- Resolves 0.1 lb-ft and 0.2 lb-ft
- 6000 lb-ft capacity
- Adapts to 14"-18" wheels
- Environmentally protected
- Temperature compensated
- Rugged stainless steel construction
- Configured to reduce magnetic sensitivity



Description

Michigan Scientific's *TW12.8HRMS175* and *TW12.8HRMS800* are highly sensitive torque transducers. Ideal for measuring small variations in wheel torque on both passenger cars and light duty trucks, these units provide one channel of torque data, and are designed to attach to adapters that simulate production wheel rims. The adapter system is fabricated by generating a profile of the original wheel rim, and designing a hub adapter and rim adapter that duplicate the critical dimensions of the original rim. The versatility of this system allows the torque transducer to be used with various wheel rim designs.

The *TW12.8HRMS175* and the *TW12.8HRMS800* wheel torque transducers measure up to 175 lb-ft and 800 lb-ft and resolve 0.1 lb-ft and 0.2 lb-ft respectively. Mechanical protection allows the transducer to be used under normal driving conditions. Torque and combined steer/camber moment overload ratings of each transducer is 6000 lb-ft. These models are geometrically configured to be used with the same adapters as the other TW12.8 models.

High grade stainless steel material and weatherproof sealing provide excellent resistance to corrosion and environmental conditions. Temperature compensation ensures stable output throughout a wide temperature range. All wires are precisely located to reduce sensitivity to magnetic effects.

Specifications

	TW12.8HRMS175	TW12.8HRMS800
Maximum Load Capacity	6000 lb-ft (8136 N-m)	6000 lb-ft (8136 N-m)
Full Scale Load	175 lb-ft (237 N-m)	800 lb-ft (1085 N-m)
Full Scale Output	1.0mV/V nominal	3.0mV/V nominal
Sensor	4 arm strain gage bridge	
Nonlinearity	0.1% of full scale output	
Hysteresis	0.05% of full scale output	
Repeatability	0.05% of full scale output	
Zero Balance	Within $\pm 5.0\%$ of rated output at zero load	
Bridge Resistance	180 Ω nominal	
Temperature Range, Compensated*	75°F to 200°F (24°C to 93°C)	
Temperature Effect on Zero	0.0008% full scale/ °F (0.0015% full scale/ °C)	
Temperature Range, Useable (Short Term)	-40°F to 300°F (-40°C to 149°C)	
Temperature Range, Useable (Long Term)	-40°F to 250°F (-40°C to 121°C)	
Excitation Voltage, Maximum	10V DC or AC rms	
Insulation Resistance, Bridge/Case	Exceeds 5000 M Ω	
Output Connector	Bendix PT02E-8-4P	
Mating Connector	Bendix PT06E-8-4S (SR)	

* Contact factory for other compensated ranges

8500 Ance Road
Charlevoix, MI 49720
Tel: 231-547-5511
Fax: 231-547-7070

Rev: 10/10/03

MICHIGAN SCIENTIFIC
<http://www.michsci.com>
Email: mscinfo@michsci.com
corporation

321 East Huron Street
Milford, MI 48381
Tel: 248-685-3939
Fax: 248-684-5406

High Resolution Wheel Torque Transducer

TW12.8HRMS175, TW12.8HRMS800 Configuration

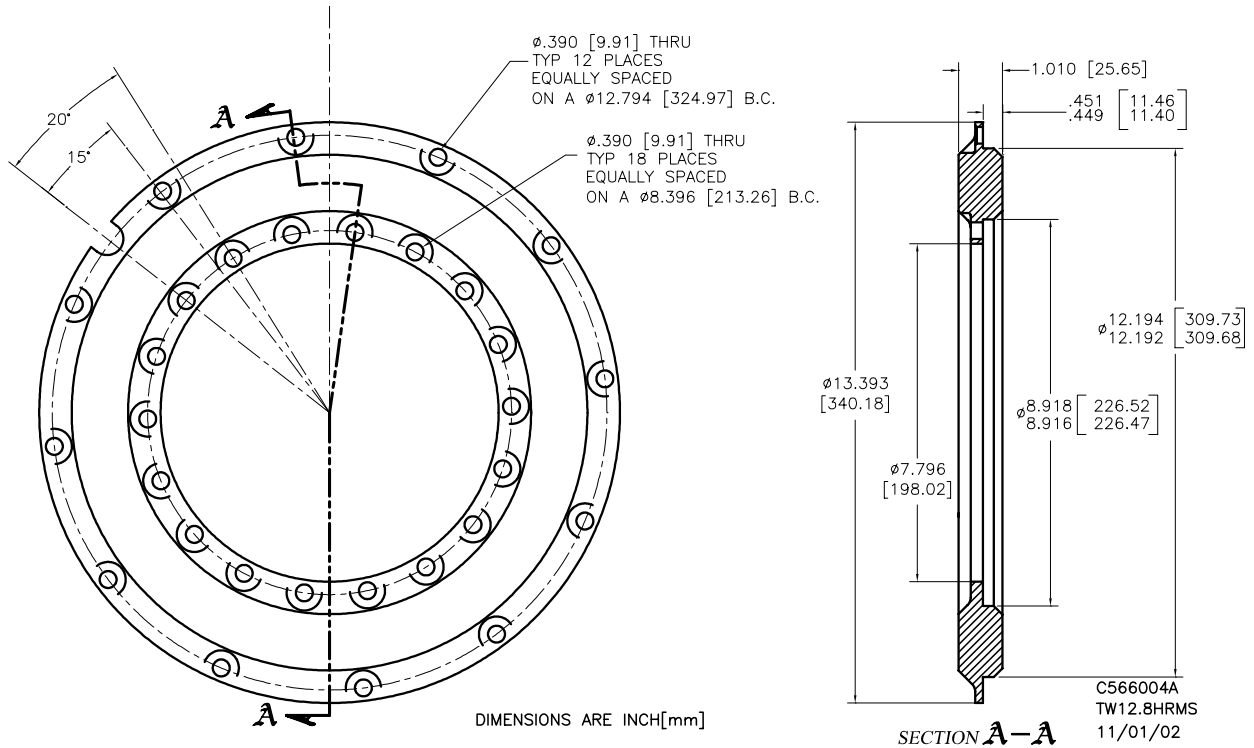

Ordering Options

Special units are available for high temperature applications.

Custom designs with alternative output sensitivities and load capacities may also be ordered.

Michigan Scientific offers a fully weatherproof slip ring, encoder, and amplifier instrumentation assembly to be used with all wheel torque transducers. Refer to the product literature section "Instrumentation Assemblies" for more information

8500 Ance Road
Charlevoix, MI 49720
Tel: 231-547-5511
Fax: 231-547-7070
Rev: 10/10/03

MICHIGAN SCIENTIFIC
<http://www.michsci.com>
Email: mscinfo@michsci.com
corporation

321 East Huron Street
Milford, MI 48381
Tel: 248-685-3939
Fax: 248-684-5406