

Wheel Load Transducer, 6-Axis

Model LW15.0

- 14,000 lb (62.2 kN) radial load capacity
- 7,000 lb (31.1 kN) lateral load capacity
- Measures 3 forces and 3 moments
- Adapts to 15"-20" wheels
- Low cross axis sensitivity
- Environmentally protected
- Temperature compensated
- Rugged stainless steel construction
- Configured to minimize magnetic sensitivity



Description

The *LW15.0 Wheel Load Transducer* is capable of measuring all of the wheel forces and moments on passenger cars and light duty trucks. It provides independent output signals for vertical, lateral, and longitudinal forces as well as camber, steer, and torque moments.

The *LW15.0 Wheel Load Transducer* uses the same inner and outer bolt patterns as the *TW15.0 Wheel Load Transducer*. It can therefore be used with wheel and hub adapters that may already exist when additional force and moment measurements are required.

An amplifier package bolts directly onto the *LW15.0 Wheel Load Transducer*. The amplifiers provide high level signals and remote electrical calibration on the rotating side of a slip ring.

High grade stainless steel material and weatherproof sealing combine to provide excellent resistance to corrosion and environmental conditions making it ideal for on-road measurements, or it can be used to monitor and control laboratory tests. Temperature compensation of the *LW15.0 Wheel Load Transducer* ensures stable output throughout a wide temperature range. In addition, all wires are precisely located to reduce sensitivity to magnetic effects.

Specifications

Maximum Force Capacity [Fx, Fz] Radial	14,000 lb (62.2 kN)
[Fy] Lateral at Tire Patch	7,000 lb (31.1 kN)
Maximum Torque Capacity, [Mx, My, Mz]	7,000 lb-ft (9.5 kN-m)
Full Scale Output	0.8 mV/V nominal
Sensor	4 arm strain gage bridge
Nonlinearity	<1% of full scale output
Hysteresis	<0.5% of full scale output
Repeatability	Within 1% of full scale output
Zero Balance	Within $\pm 1\%$ of rated output
Cross Axis Sensitivity	<1.5% of full-scale output with amplifier
Radial Sensitivity Variation	<1% of full scale output
Bridge Resistance	175 to 1400 Ω , axis dependent
Temperature Range, Compensated	-40°F to 200°F (-40°C to 93°C)
Operating	-40°F to 257°F (-40°C to 125°C)
Insulation Resistance, Bridge/Case	Exceeds 1000 M Ω

8500 Ance Road
Charlevoix, MI 49720
Tel: 231-547-5511
Fax: 231-547-7070

Rev: 2/1/05

MICHIGAN SCIENTIFIC
<http://www.michsci.com>
Email: mscinfo@michsci.com
corporation

321 East Huron Street
Milford, MI 48381
Tel: 248-685-3939
Fax: 248-684-5406

Wheel Load Transducer, 6-Axis

LW15.0 Configuration

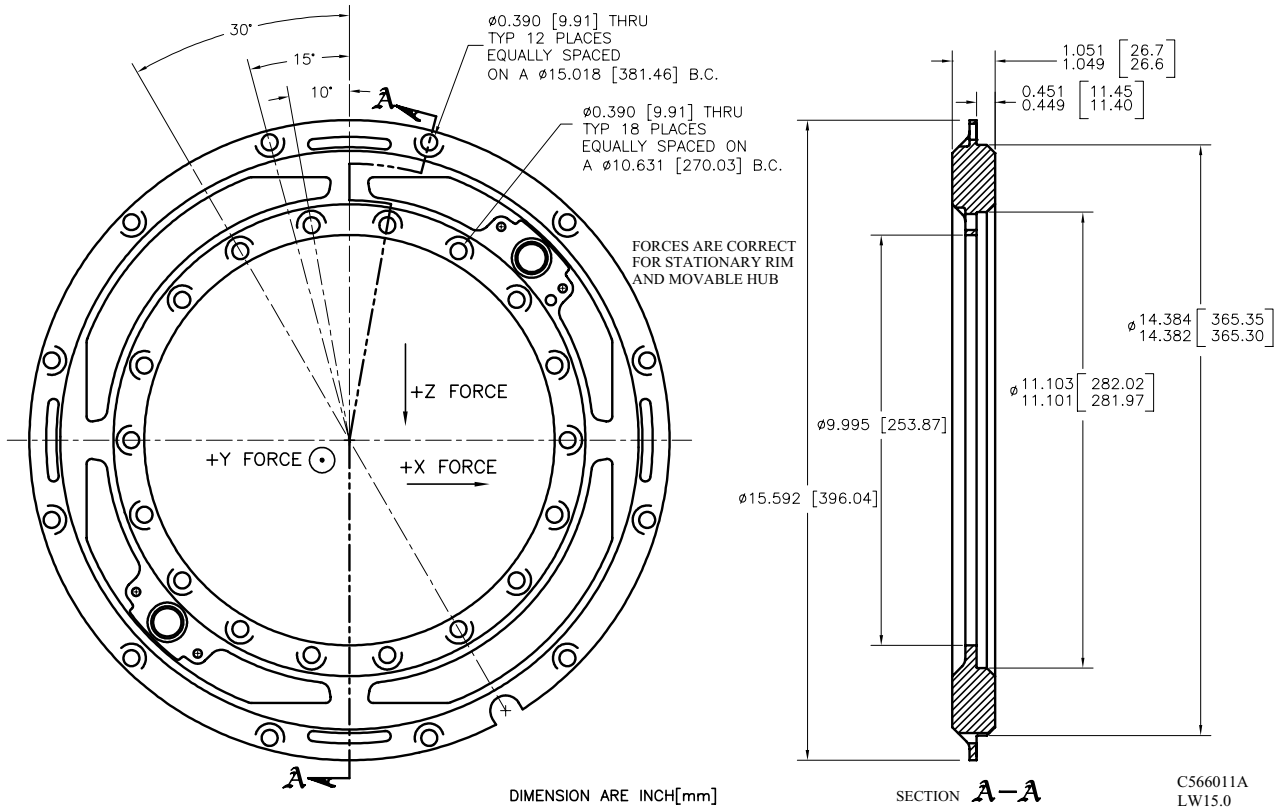

Ordering Options

Custom designs with alternative output sensitivities and load capacities may also be ordered.

Michigan Scientific offers a fully weatherproof slip ring, resolver, and amplifier instrumentation assembly to be used with all wheel torque or load transducers. Refer to the product literature section "Instrumentation Assemblies" for more information.

8500 Ance Road
 Charlevoix, MI 49720
 Tel: 231-547-5511
 Fax: 231-547-7070
 Rev: 2/1/05

MICHIGAN SCIENTIFIC
<http://www.michsci.com>
 Email: mscinfo@michsci.com
corporation

321 East Huron Street
 Milford, MI 48381
 Tel: 248-685-3939
 Fax: 248-684-5406