

# Weatherproof Slip Ring & Encoder Assembly

## Model SR10AW/E60/A

- 10 circuit weatherproof slip ring
- 60 pulse encoder
- Color coded terminals
- Lightweight and compact
- Permanently lubricated bearings
- Rugged stainless steel construction
- Instrumentation quality rings and brushes



### Description

The Michigan Scientific *SR10AW/E60/A Weatherproof Slip Ring and Encoder Assembly* is used for applications requiring both a sealed slip ring and an encoder. It is designed to mount on the end of a rotating shaft, and make an electrical connection to strain gages, thermocouples, or other rotating sensors, while simultaneously providing pulses to measure rotational speed. Specially designed seals provide complete weatherproof protection from water, dust, and other contaminants. The slip ring brushes and rings are made of precious metals, which minimize noise and enable the assembly to be used for low level instrumentation signals.

The *SR10AW/E60/A* accepts up to 10 circuit connections and incorporates a pulse encoder that enables rotational speed to be measured. The encoder generates a 60 pulse per revolution square wave signal with a range of 0 to 6000 RPM. Since the pulses per second are equivalent to RPM, rotor speed can be recorded directly from a frequency display without scale conversion. Analog output signals for rotational speed can be obtained by using this slip ring and encoder model with Michigan Scientific's frequency to voltage encoder electronics.

Connections to the slip ring rotor are made through a military style connector. For complete weatherproofing of this assembly, it must be used with a sealed metal cap or rubber boot to protect the terminals on the slip ring stator. Both of these options incorporate a military style connector, enabling all connections to the slip ring and encoder to be made through connectors. In addition, permanently lubricated bearings eliminate the need for routine cleaning and maintenance.

### Specifications

Circuits	10
Current Capacity	500 mA
Temperature Range*	-40°F to 212°F (-40°C to 100°C)
RPM Rating	2000 RPM
Maximum Peak Noise**	0.1Ω
Weight	7.5 oz. (213 g)
*For operation below 0°F, specify low temperature lubricant.	
** Resistance variation across slip ring contact.	

8500 Ance Road  
Charlevoix, MI 49720  
Tel: 231-547-5511  
Fax: 231-547-7070  
Rev: 8/27/03

**MICHIGAN SCIENTIFIC**  
<http://www.michsci.com>  
Email: [mscinfo@michsci.com](mailto:mscinfo@michsci.com)  
corporation

321 East Huron Street  
Milford, MI 48381  
Tel: 248-685-3939  
Fax: 248-685-5406

# Weatherproof Slip Ring & Encoder Assembly

## SR10AW/E60/A Configuration

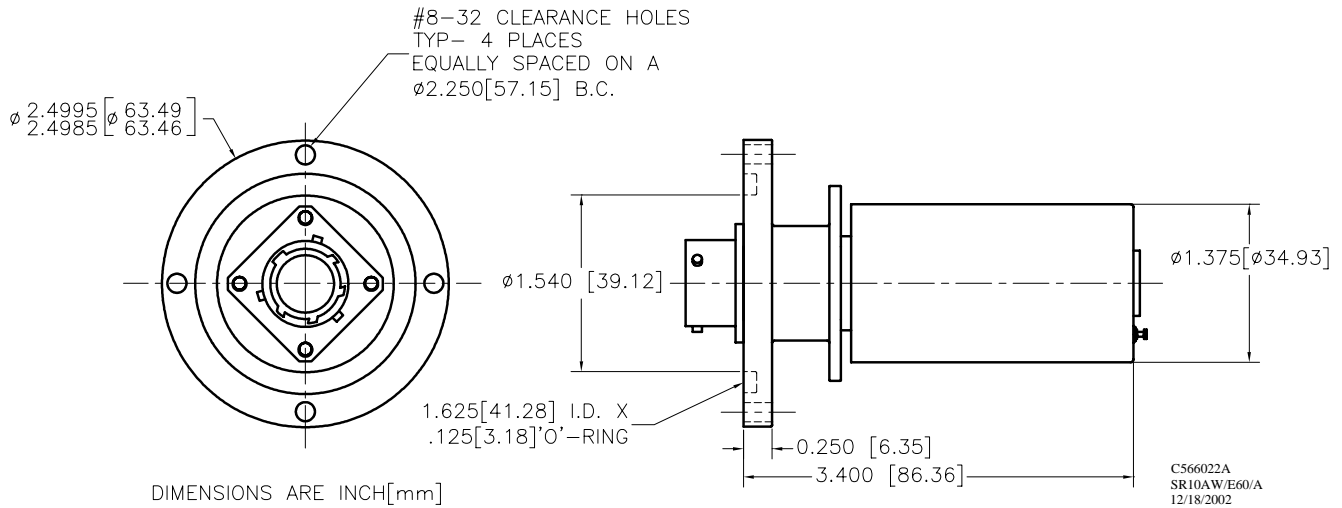

## Mounting

The *SR10AW/E60/A* can easily be mounted to the end of a shaft. Refer to the literature in the “Instrumentation Assemblies,” and “Price List and Accessories” sections for examples of mounting adapters.

Contact Michigan Scientific for applications where the slip ring assembly is subjected to extreme vibration.

## Ordering Options

For information regarding slip ring accessories, refer to the “Price List and Accessories” section.