

AC Remote Amplifier Control Unit

Model PS-AC

- Powers up to 18 spinning strain gage amplifiers*
- Remote bridge excitation On/Off capability
- Remote electronic shunt calibration capability
- Bipolar power supply for spinning amplifiers
- Ideal for laboratory applications



Description

Michigan Scientific's *AC Remote Amplifier Control Unit* is a complete system for controlling all Michigan Scientific Spinning Amplifiers. The *PS-AC* powers the amplifiers, controls excitation to strain gage bridges, and commands spinning strain gage amplifiers to apply their internal shunt calibration resistor to the appropriate arm of the strain gage bridge. The bridge excitation off feature allows the user to detect self-generated system response (noise) from undesired environmental conditions.

*5 Volt bridge excitation @ 350 Ω

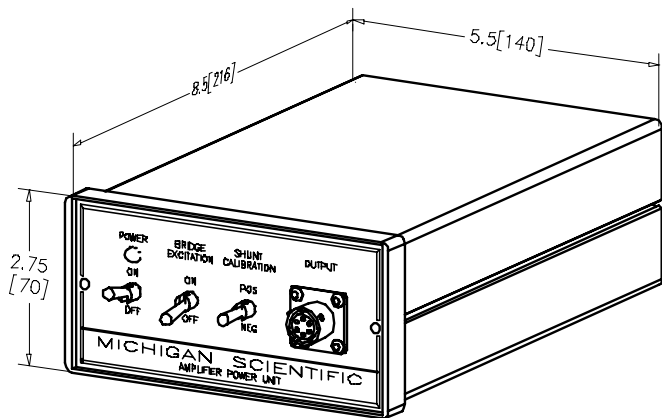

DIMENSIONS ARE INCH[mm]

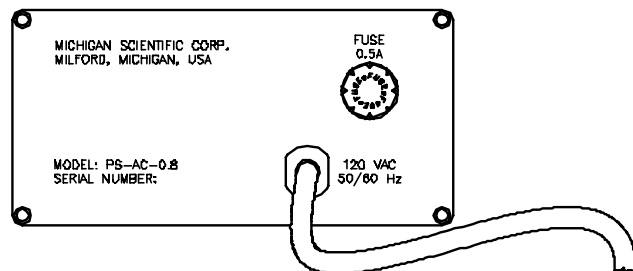

REAR PANEL

C566039A
PS-AC
12/27/2002

8500 Ance Road
Charlevoix, MI 49720
Tel: 231-547-5511
Fax: 231-547-7070
Rev: 7/12/05

MICHIGAN SCIENTIFIC
<http://www.michsci.com>
Email: mscinfo@michsci.com
corporation

321 East Huron Street
Milford, MI 48381
Tel: 248-685-3939
Fax: 248-685-5406

AC Remote Amplifier Control Unit

Specifications

PARAMETER	SPECIFICATIONS
OUTPUT	
Voltage	±15 V
Maximum Voltage Error (No Load)	± 0.75 V
Ripple and Noise Voltage (No Load)	± 60 mV
Maximum Source Resistance	0.40 Ω
Temperature Coefficient	0.30% / °C
Maximum Current	0.8 A
Maximum Transient Response	<50 μs
INPUT	
Voltage	100 - 120 VAC or 220 - 240 VAC
Frequency	50 / 60 Hz
ENVIRONMENT	
Operation	0 to +50 °C (+32 °F to +122 °F)
Storage	-40 °C to +85 °C (-40 °F to +185 °F)

Controls

Power (On/Off):	Activates the Remote Amplifier Control Unit and illuminates LED.		
Bridge Excitation (On/Off):	When used with a modular strain gage spinning amplifier, this turns the excitation to the bridge on or off without turning off the amplifier. This is done by inverting the polarity of the ± 15V supply pins.		
	Bridge Excitation ON OFF	Output Terminal A +15 VDC -15 VDC	Output Terminal C -15 VDC +15 VDC
Shunt Calibration: (Positive/Center/Negative)	Remotely applies positive or negative shunt resistance across bridge terminals when used with a modular strain gage spinning amplifier.		
	Shunt Calibration POSITIVE CENTER NEGATIVE		Output Terminal F +15 VDC High Impedance -15 VDC
Indicator LED:	Illuminated whenever power is on.		

Electrical Connections

6 PIN FEMALE BENDIX PT02E-10 6S CONNECTOR*						
Terminal	A	B	C	D	E	F
Function	+15V	15V Common	-15V	15V Common	AC Power Ground	Calibration Control

*Mating connector is provided with new units

8500 Ance Road
Charlevoix, MI 49720
Tel: 231-547-5511
Fax: 231-547-7070
Rev: 7/12/05

MICHIGAN SCIENTIFIC
<http://www.michsci.com>
Email: mcsinfo@michsci.com
corporation

321 East Huron Street
Milford, MI 48381
Tel: 248-685-3939
Fax: 248-685-5406