

Twelve Channel Strain Gage Spinning Amplifier

Model AMPEH2-HS_I

- Integrated weatherproof slip ring and amplifier assembly
- Highly accurate, low drift, differential input
- Remote positive/negative shunt calibration
- Remote bridge excitation On/Off capability
- Designed to withstand severe vibration
- Factory set gain, excitation voltage and shunt resistor values per customer specifications



Description

Michigan Scientific's *Twelve Channel Strain Gage Spinning Amplifier* provides signal conditioning for up to twelve channels of strain gage data channels. This system is ideal for use on heavy duty rotating equipment. Superior data accuracy is achieved by locating the signal amplifiers on the rotating side of the slip ring. This configuration greatly improves signal quality because the amplifiers are located close to the sensor which reduces errors due to long lead wires, connector resistance variations, and electromagnetic interference.

Each amplifier gain, bridge excitation voltage, and shunt calibration resistance can be independently set at the factory according to customer specifications. Features include remote positive/negative shunt calibration and bridge excitation on/off. All electrical components are sealed from the environment and suspended in a rugged enclosure designed to protect the components from vibration. The *Twelve Channel Strain Gage Spinning Amplifier* is ideally suited to be used in conjunction with Michigan Scientific's model *PS-AC-BF16 Amplifier Control and Filter System*.

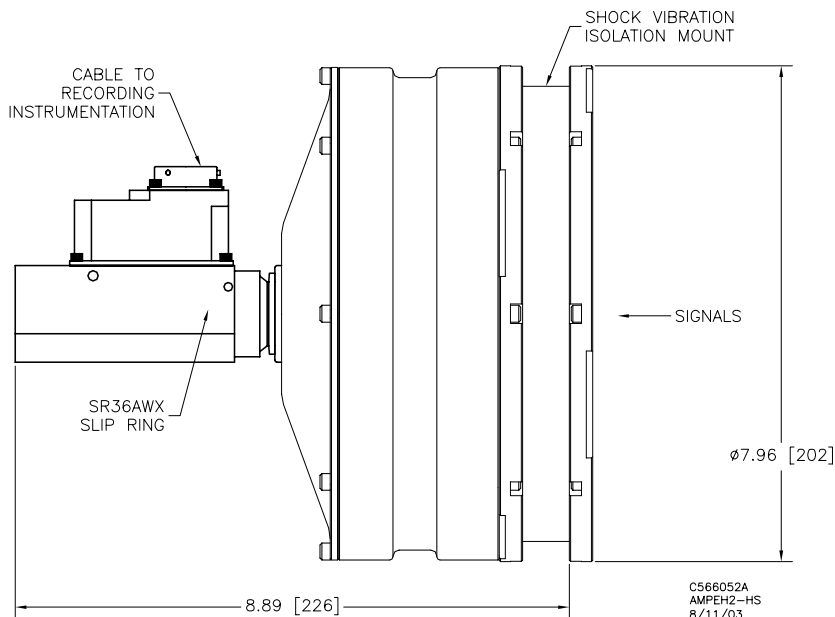

8500 Ance Road
Charlevoix, MI 49720
Tel: 231-547-5511
Fax: 231-547-7070
Rev: 8/11/03

MICHIGAN SCIENTIFIC
<http://www.michsci.com>
Email: mscinfo@michsci.com
corporation

321 East Huron Street
Milford, MI 48381
Tel: 248-685-3939
Fax: 248-685-5406

Twelve Channel Strain Gage Spinning Amplifier

AMPEH2-HS Specifications

PARAMETER	SPECIFICATION
BRIDGE EXCITATION	Customer specified excitation level
Type	Constant Voltage
Magnitude	5,10, or 17 V
Current Limit	100 mA
Temperature Coefficient	0.0005%/°C Max (0.00028 %/°F)
REMOTE CALIBRATION	Positive & negative solid state shunt calibration
Shunt value range	100 kΩ or greater
Shunt accuracy	0.1% or better
GAIN	Customer specified
Range	1 to 10,000 V/V
Accuracy @ 25°C, Gain =500	± 2%
Temperature Coefficient	0.0014%/ °C
OUTPUT	
Range	±10 V
Capacitive Load	1000 pF Max
VOLTAGE OFFSET*	Referred to input of amplifier
Initial** @ 25°C, Gain = 500	±15 μV
Temperature Stability @ Gain = 500	± 0.2 μV /°C
Time Stability @ Gain = 500	±1.0 μV / Month
INPUT VOLTAGE	
Range	Varies with configuration
CMRR @ DC	128 dB
CMRR @ 60 Hz / 100 Hz	110 dB @ 100 Hz
NOISE	Referred to input of amplifier
0.01 - 10 Hz	0.8 μV p-p
DC - 1 Hz	--
DYNAMIC RESPONSE	
Frequency Response ± 3 dB / 1%	10 kHz / 1 kHz @ Gain 100
Slew rate	0.6 V/ μs
Settling Time 0.1% / 0.01% @ Gain=100	80 μs / 150 μs
POWER REQUIREMENTS	
Voltage @ 25°C	±13 to ±17 VDC
Current	±15 mA plus Bridge Load (+15 mA additional during shunt calibration)
POWER REQUIREMENTS	
Voltage	± 15 VDC
Current	± 30 mA plus Bridge Load
ENVIRONMENT	
Specification	-25 to +85°C (-13 to +185°F)
Operation	-55 to +125°C (-67 to +257°F)
Storage	-65 to +150°C (-85 to +302°F)
* Upon bridge excitation voltage	
** Average (channel to channel)	

8500 Ance Road
 Charlevoix, MI 49720
 Tel: 231-547-5511
 Fax: 231-547-7070
 Rev: 8/11/03

MICHIGAN SCIENTIFIC
<http://www.michsci.com>
 Email: mscinfo@michsci.com
corporation

321 East Huron Street
 Milford, MI 48381
 Tel: 248-685-3939
 Fax: 248-685-5406