

# Wheel Torque Transducer Instrumentation Assembly

- Integrated weatherproof torque transducer, slip ring, encoder, and amplifier assembly
- Weatherproof torque transducer available in a variety of load capacities\*
- High accuracy encoder with outputs of 60, 256, 360, 500 or 512 ppr
- 10 circuit weatherproof slip ring with 5 data channel capacity
- Precision strain gage and/or thermocouple spinning amplifiers
- Thermocouple amplifier available in all thermocouple types
- Strain gage amplifier provides bridge power, electronic shunt calibration, and “bridge excitation off” feature
- Slip ring/encoder/amplifier assembly adapts to a variety of wheel bolt circle patterns
- Durable construction
- Customized to meet user’s testing requirements



## Description

Michigan Scientific’s *Wheel Torque Transducer Instrumentation Assembly* is ideal for collecting data in wheel applications. The assembly consists of a wheel torque transducer that provides one channel of torque data, a 10 circuit weatherproof slip ring with pulse encoder, and can accommodate multiple strain gage and thermocouple spinning amplifiers all enclosed in a weatherproof housing. The torque transducer attaches to adapters that simulate production wheel rims. The adapter system is fabricated by generating a profile of the original wheel rim and designing a hub adapter and rim adapter that duplicate the critical dimensions of the original rim. The hub adapter fastens to the interior bolt circle of the torque transducer and the rim adapter fastens to the exterior bolt circle.

Superior data accuracy is achieved by locating precision amplifiers on the rotating side of the slip ring. This configuration greatly improves signal quality because the amplifier is located closer to the sensor which reduces errors due to long lead wires, connector resistance variations, electro-magnetic interference, and temperature gradients across slip ring contacts.

The slip ring/encoder/amplifier assembly includes an adapter plate designed to adapt to a variety of wheel bolt circle patterns. Wire connections are sealed on the stationary end of the slip ring by utilizing a weatherproof metal cap with a military style connector. All components in the assembly are durable and designed to withstand severe testing environments.

The *Wheel Torque Transducer Instrumentation Assembly* can be customized to meet the user’s testing requirements. If additional strain gage and/or thermocouple channels are required, higher channel capacity slip ring models are available. The additional amplifiers may be arrayed around the wheel adapter plate.

\* See product literature on Transducers for wheel torque transducer information.

8500 Ance Road  
Charlevoix, MI 49720  
Tel: 231-547-5511  
Fax: 231-547-7070  
Rev: 7/18/05

**MICHIGAN SCIENTIFIC**  
<http://www.michsci.com>  
Email: [mscinfo@michsci.com](mailto:mscinfo@michsci.com)  
corporation

321 East Huron Street  
Milford, MI 48381  
Tel: 248-685-3939  
Fax: 248-685-5406

# Wheel Torque Transducer Instrumentation Assembly

## Wheel Configuration

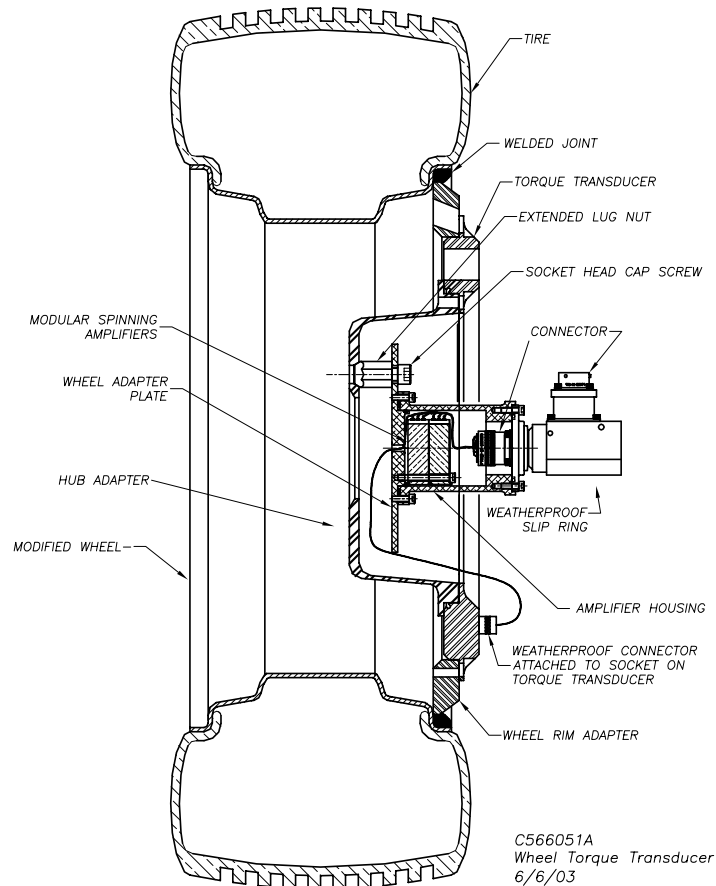

## Slip Ring Restraint Configuration

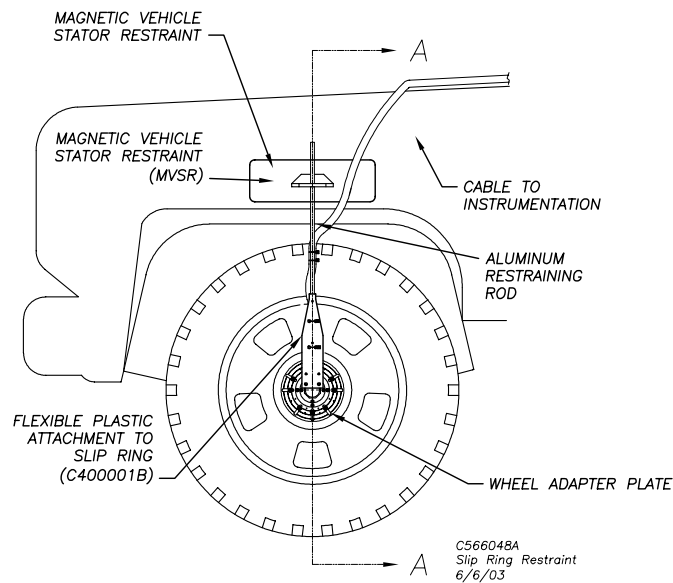

8500 Ance Road  
Charlevoix, MI 49720  
Tel: 231-547-5511  
Fax: 231-547-7070  
Rev: 7/18/05

**MICHIGAN SCIENTIFIC**  
<http://www.michsci.com>  
Email: [mscinfo@michsci.com](mailto:mscinfo@michsci.com)  
corporation

321 East Huron Street  
Milford, MI 48381  
Tel: 248-685-3939  
Fax: 248-685-5406