

STRAIN GAGE SLIP RING CIRCUITS

Excellent quality strain gage signals can be obtained through slip ring connections. Slip ring properties and circuit configuration both have important influence upon signal quality. Strain gage based Wheatstone bridge circuits are categorized into three basic configurations: full bridge (four active bridge arms), half bridge (two active bridge arms), and quarter bridge (one active bridge arm). When used with slip rings, these configurations can be further categorized based upon the number of bridge arms located on the spinning side of the slip ring. Some frequently used slip ring circuit configurations are discussed here.

All Four Bridge Arms Located on Spinning Side of Slip Ring

This configuration consistently produces excellent quality signals and is compatible with most strain gage amplifier equipment. Conventional balance and calibration networks may be used, but are omitted for clarity from the representative diagram shown in Figure 1.

Slip ring noise in strain gage circuits is caused by slight variation in the ring connection resistance. With all four bridge arms located on the spinning side of the slip ring, the rings are located external to the bridges and cannot affect bridge balance thereby greatly reducing sensitivity to slip ring resistance variation. With this configuration peak ring noise is less than 0.1% of the data signal when used with any Michigan Scientific slip ring assembly.

The numbers of data channels attainable with this configuration and various slip ring models are tabulated below. The parallel excitation ring requirement (used to remain within ring current limits) are also shown, assuming 120 ohm gages.

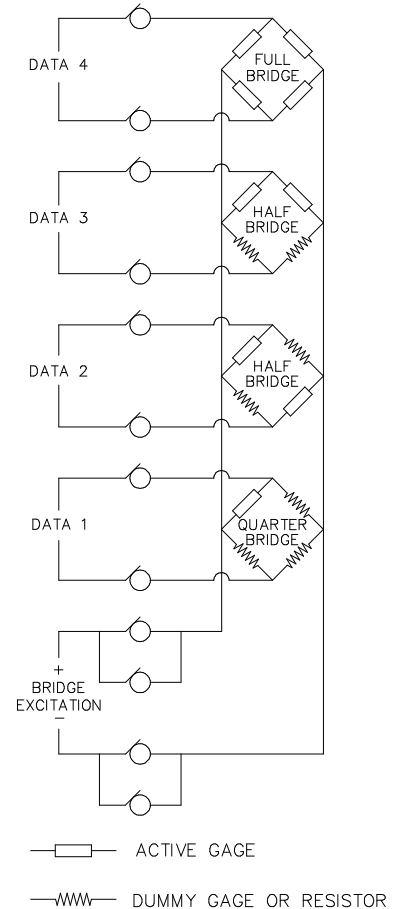

Figure 1: Representation of the “all four bridge arms on spinning side of slip ring” circuit configuration with multiple data signals.

Data channel capacity and excitation rings required vs. slip ring model

Slip Ring Model	10 Volt Excitation				5 Volt Excitation			
	S4	SR10M	SR20M	SR36M	S4	SR10M	SR20M	SR36M
Bridges @ 120 ohms	1	4	8	13	1	4	9	15
Excitation rings required	2	2	4	10	2	2	2	6

One Bridge Arm Located on Spinning Side of Slip Ring

The only kind thing that can be said for this configuration is that it can yield a lot of data with a few rings.

As shown in Figure 2, the rings are in series with the gage so any resistance variation at the rings has the same effect upon the output as a change in gage resistance. If multiple data signals are measured as shown, the common ring should be paralleled to reduce noise if any extra rings are available and *must* be paralleled to limit ring current if many gages are used. Signal to ring noise ratio is independent of excitation voltage, but higher gage resistance and gage factor are beneficial.

This configuration should be used only when large strain signals are expected and rather high noise is acceptable. There are more elaborate single gage circuit configurations which produce better quality data, however, the improvement is rarely worth the complication.

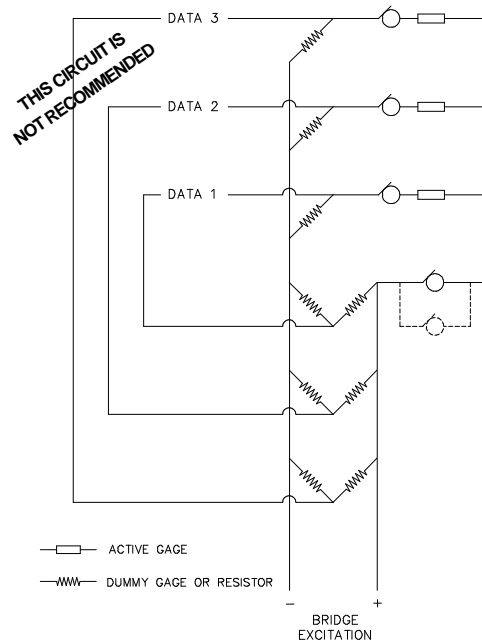

Figure 2: Representation of the “one bridge arm on spinning side of slip ring” circuit configuration with multiple data signals.

Two Bridge Arms Located on Spinning Side of Slip Ring

This configuration is used only because it is convenient with most strain gage amplifier equipment.

As shown in Figure 3, the common excitation rings are within the bridges, thus any ring resistance variation will cause a change in bridge balance. The data signal rings are not critical since the input impedance of the data instrumentation is taken to be infinite (i.e. negligible current flows through these rings). Any extra rings should be paralleled with the excitation rings to reduce noise even if ring current is within limits.

This configuration produces somewhat less noise than the “one bridge arm on spinning side” configuration discussed above but is far more susceptible to ring noise than the “all four bridge arms on spinning side” configuration discussed earlier or the chevron configuration we discuss next.

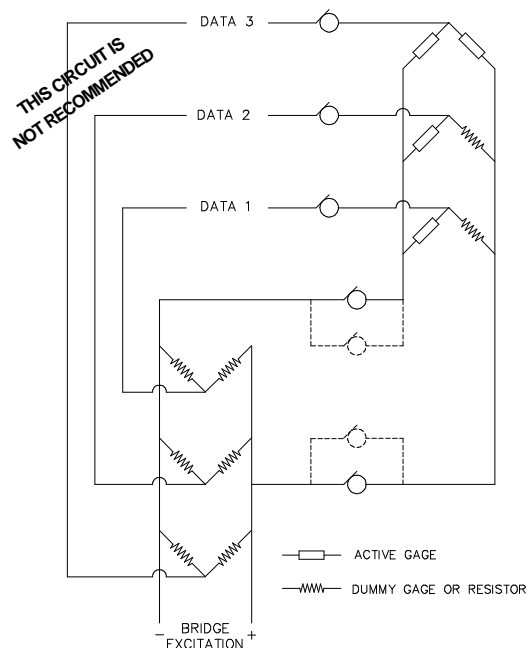

Figure 3: Representation of the “two bridge arms on spinning side of slip ring” circuit configuration with multiple data signals.

The Chevron Bridge Circuit

This configuration requires fewer rings than the “all four arms on spinning side” configuration and has excellent noise characteristics. (Note that technically, all four bridge arms are on the spinning side of the slip ring in this configuration also.) Peak ring noise is less than 0.1% of the data signal when used with any Michigan Scientific slip ring assembly, however, interaction of the bridge signals must be considered.

Circuits that share bridge completion arms (A & B as shown in Figure 4) are subject to crosstalk. The crosstalk results from signal current in the common arms which causes a shift in voltage of the common signal reference junction (point C). Each output is affected by the signal currents in every other output. The crosstalk from all the other signals is algebraically cumulative upon any one output.

The interaction will be least with high instrumentation input impedance. The crosstalk that will appear in every other bridge output due to a signal in one bridge is as follows:

N	10	100	1000	10000
Crosstalk	4.6%	0.5%	0.05%	0.005%

Where: $N = \frac{\text{Instrumentation Input Impedance}}{\text{Gage Resistance}}$

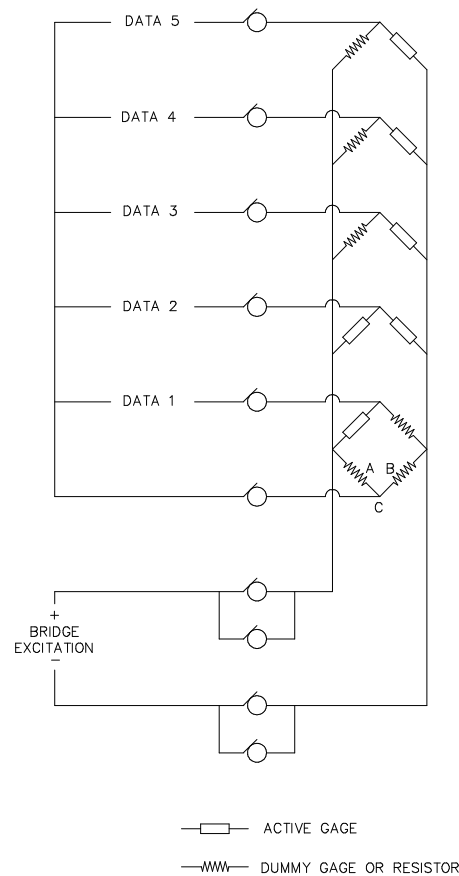

Figure 4: Representation of chevron slip ring circuit.

Example: With 120 ohm gages and an amplifier with a 12,000 ohm input impedance connected to DATA 5 output, a crosstalk voltage of 0.5% of the DATA 5 output voltage will appear at every other output, superimposed on any strain signal from that bridge and crosstalk from other loaded bridges.

Often the outputs of multi-bridge circuits are sampled sequentially. In that case there is no interaction since signal currents do not exist in any of the bridges other than the one connected to the output instrument at the time. This suggests a method of testing for crosstalk when simultaneous data is required. A temporary disconnection of one readout instrument should not cause significant changes in the other output signals.

Chevron circuit data channel capacity and excitation ring requirements are as follows:

Slip Ring Model	10 Volt Excitation				5 Volt Excitation			
	S4	SR10M	SR20M	SR36M	S4	SR10M	SR20M	SR36M
Bridges @ 120 ohms	1	5	13	25	1	7	15	29
Excitation rings required	2	4	6	10	2	2	4	6

REPRESENTATIVE QUARTER BRIDGE CIRCUIT FOR LEAST SLIP RING NOISE AND LEAST TEMPERATURE DRIFT

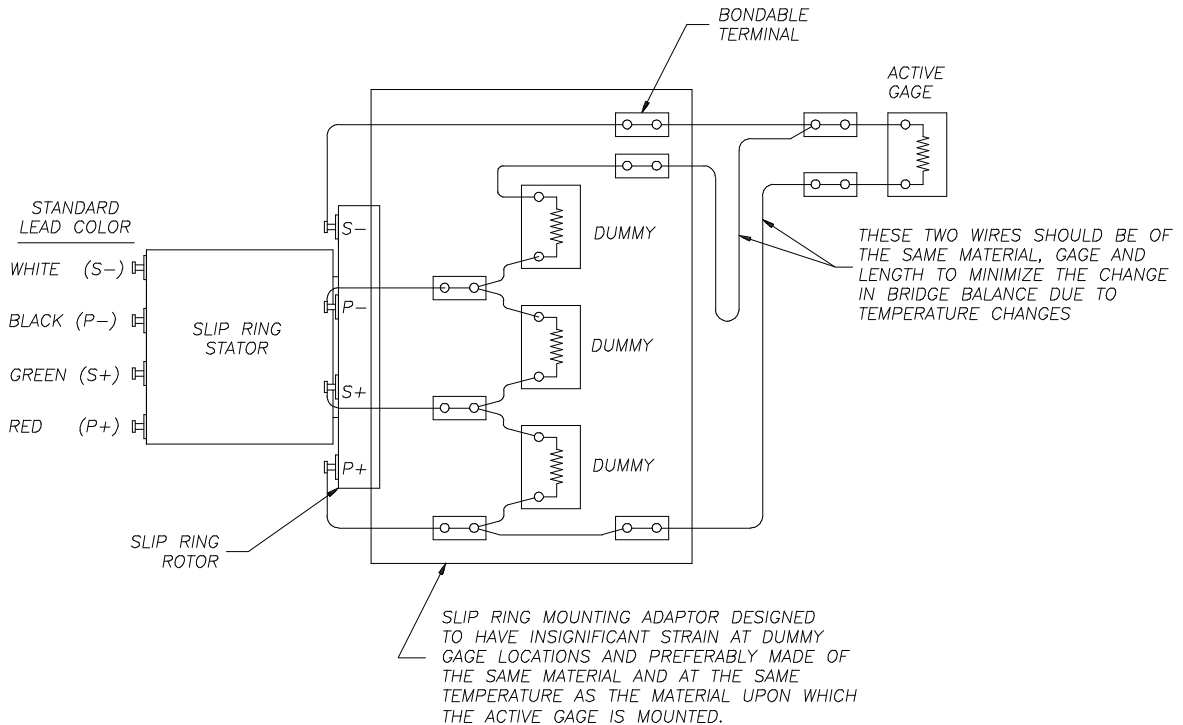

THE COMPLETE BRIDGE (EXCEPT FOR MINOR BRIDGE BALANCING RESISTORS) MUST BE ON THE ROTATING SIDE OF THE SLIP RING ASSEMBLY. ANY OTHER ARRANGEMENT IS FAR MORE SENSITIVE TO SLIP RING RESISTANCE VARIATION AND MAY RESULT IN AN UNSATISFACTORY SIGNAL TO NOISE RATIO.